

Sink Galante

Flush-mount | Top-mount | Undermount

Kitchen Sinks

Code: 3780 000



DETAILS

Edge/Installation Type Flush-mount | Top-mount | Undermount

Material AISI 304 stainless steel

Texture Brushed in line

Finish Foster brushed

Base 90 cm

Width 86 cm

Dimensions 860 x 520 mm

Bowl dimension 830 x 350 mm

Built-in hole [View technical data sheet](#)

Standard fittings Fixing hooks, gasket, drain, overflow and siphon, boxed packing

Mixer holes 1 standard hole - 2nd hole on request

Drainer No

Number of bowls 1 bowl

Waste fitting 3,5" drain

FEATURES

2nd / 3rd hole available The sink can be customized with the execution on request of additional holes, usable for double-hole mixers, for remote controlled drains or for the installation of soap dispensers. The positions are marked on the drawings with dotted line holes.

Basket 3,5" waste fitting The drain is equipped with a large 3.5" drain, with the practical basket cap that prevents the discharge of solid parts.

Deep bowls This bowls reach an important depth, over 20 cm, thanks to the advanced production technology, that can be offer great capiciency and practicity in all the washing operations.

TECHNICAL DATA

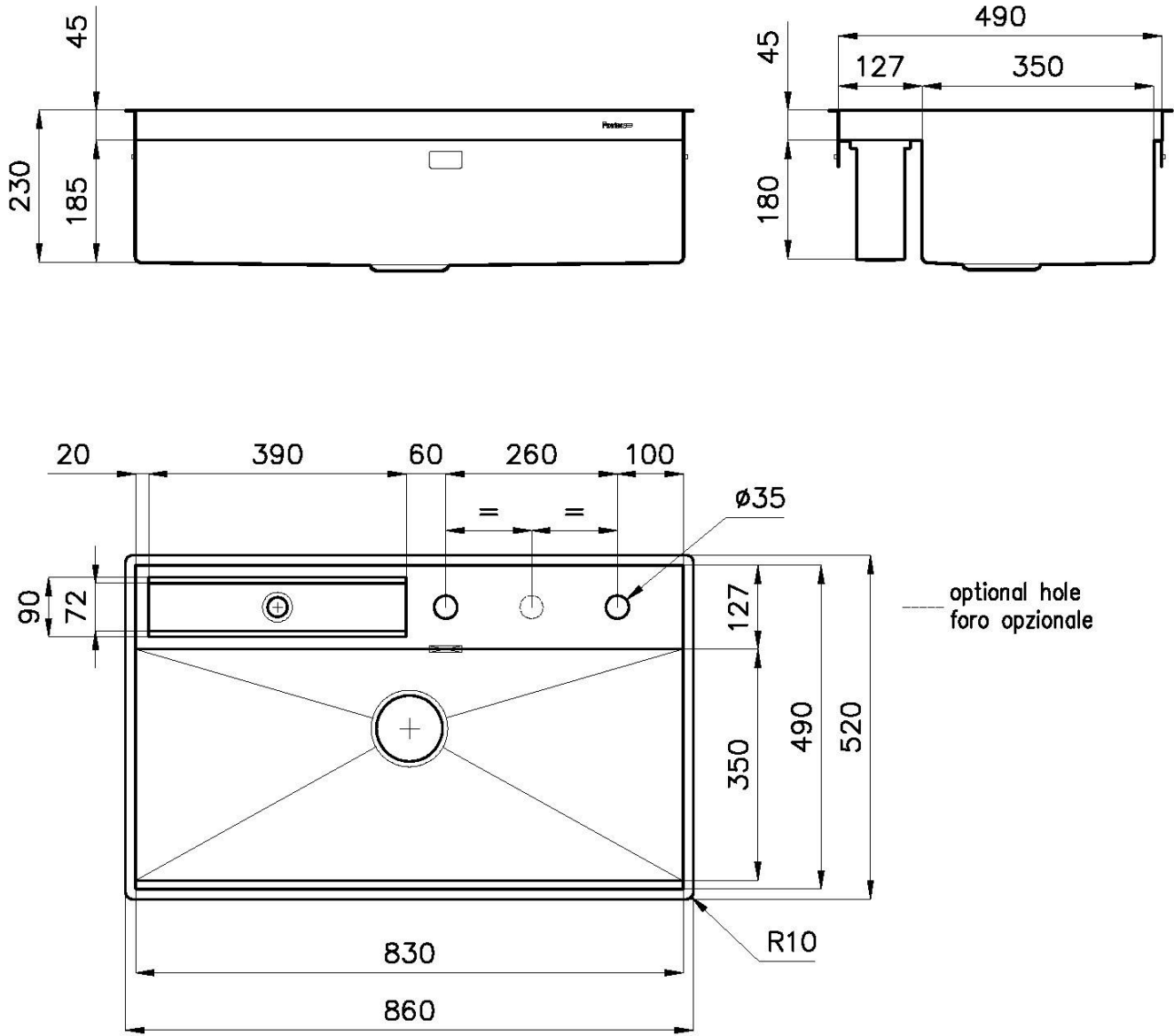

3780 000 Accessories / Accessori

The "rails" system makes it possible to use a combination of numerous accessories. Grids, chopping boards, utensils' ranging system, bowls and containers of different dimensions can be alternated in the workspace with a simple gesture, and can easily be stacked, in order to be on hand at all times.

Il sistema di "corsie" rende possibile l'utilizzo combinato di innumerevoli accessori. Griglie, taglieri, portautensili, vaschette e contenitori di varie dimensioni si alternano nella zona di lavoro con un semplice gesto e possono essere impilati, sempre a portata di mano.

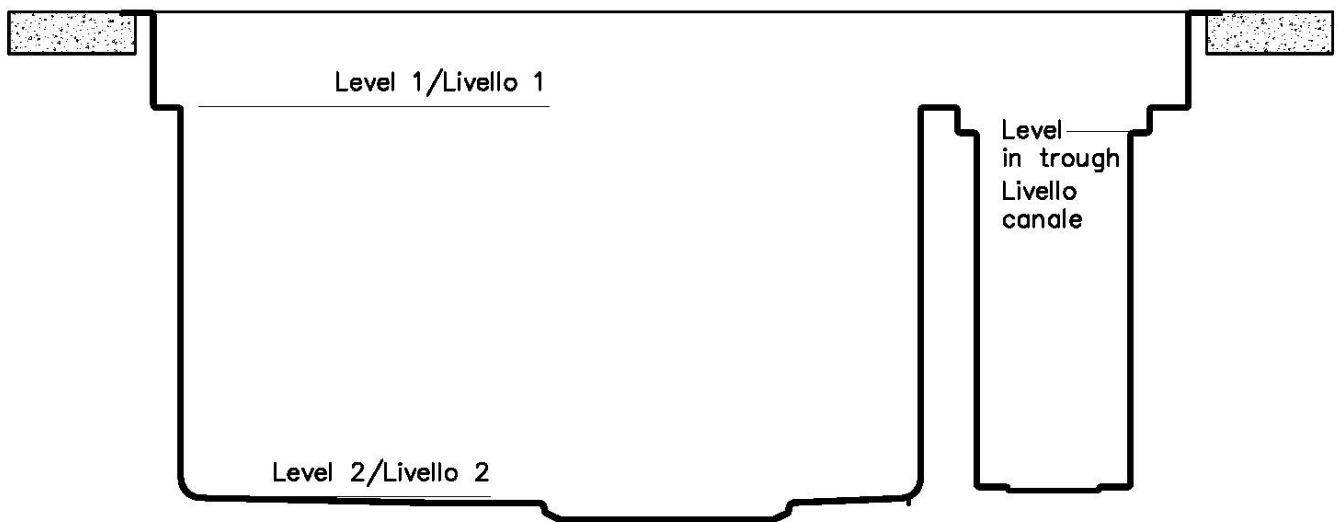

3780 000 **Level 1/Livello 1**

Compatible accessories/Accessori compatibili:

8100 618 (in dotazione/supplied with sink)

8643 117 (in dotazione/supplied with sink)

8100 305

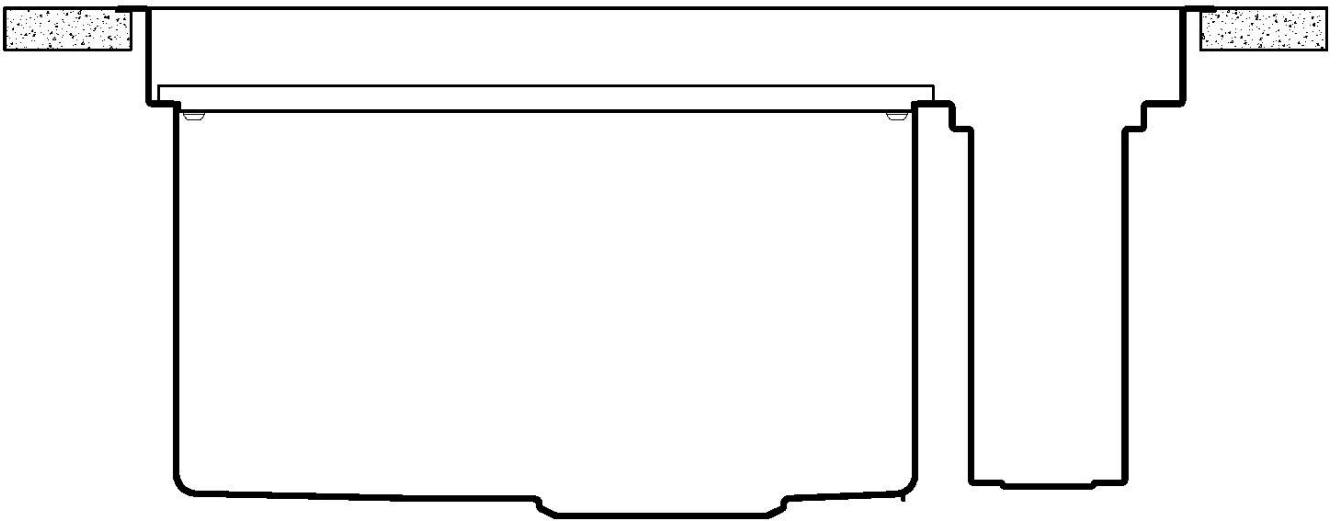

3780 000 **Level 2/Livello 2**

Compatible accessories/Accessori compatibili:

8100 618 (in dotazione/supplied with sink)

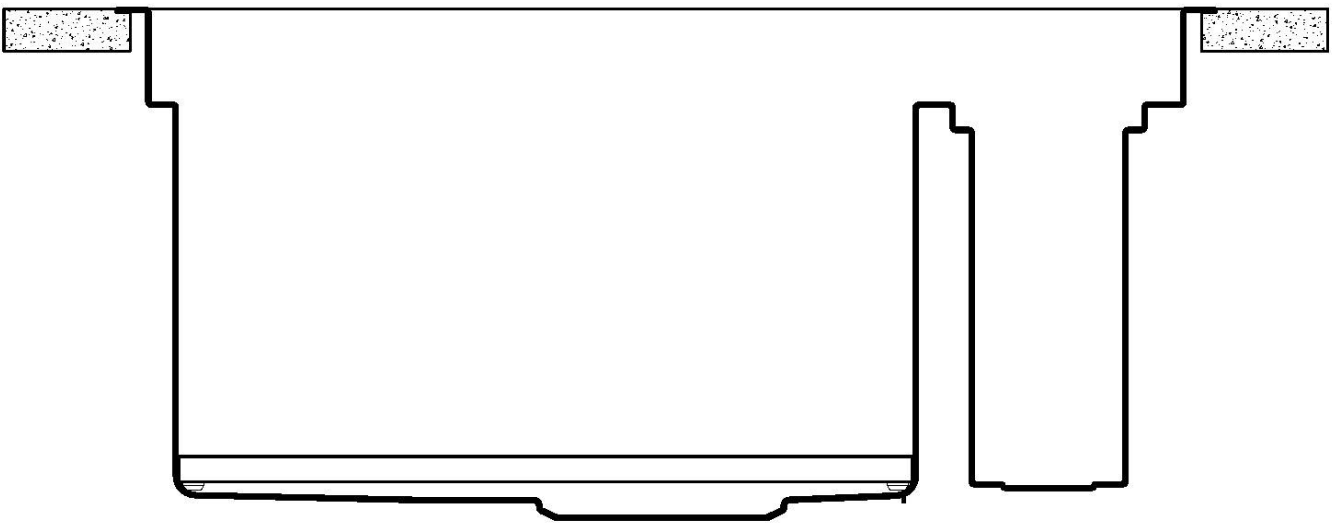

3780 000 **Level "in trough"/Livello "canale"**

Compatible accessories/Accessori compatibili:

8151 004

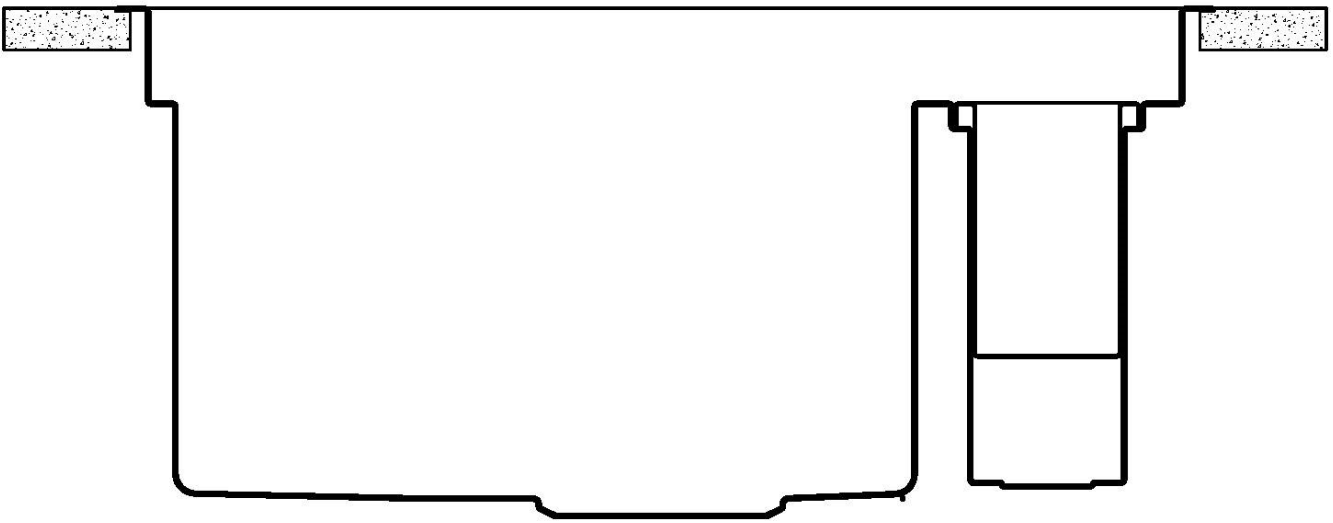

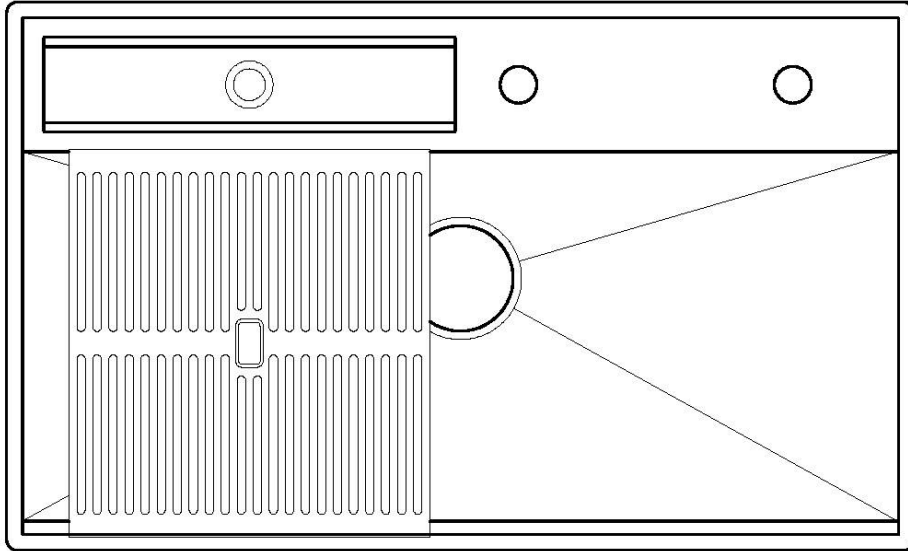

8100 618
POSIZIONATA A FILO VASCA / EDGE POSITIONING

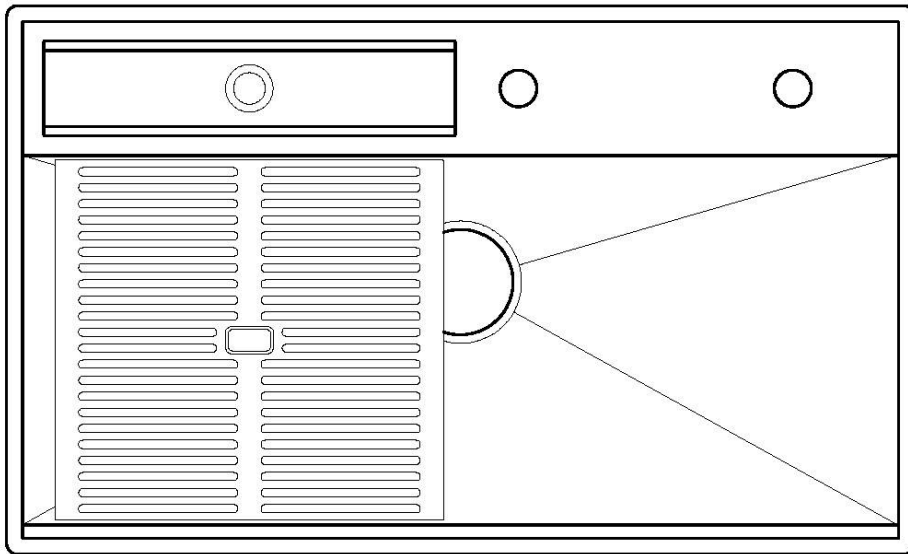

8100 618
POSIZIONATA SUL FONDO / BOTTOM POSITIONING

Filotop

FT

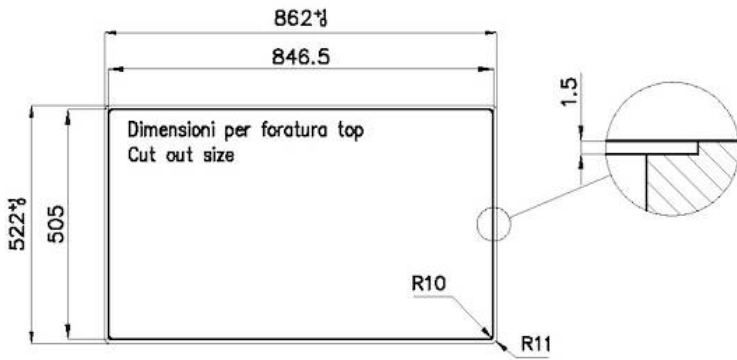

SPT

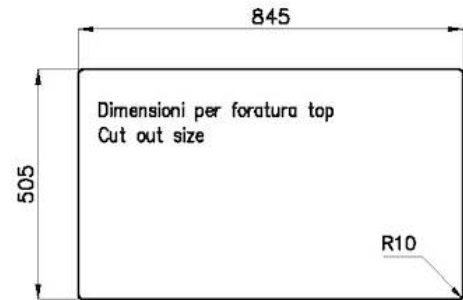

Sottotop

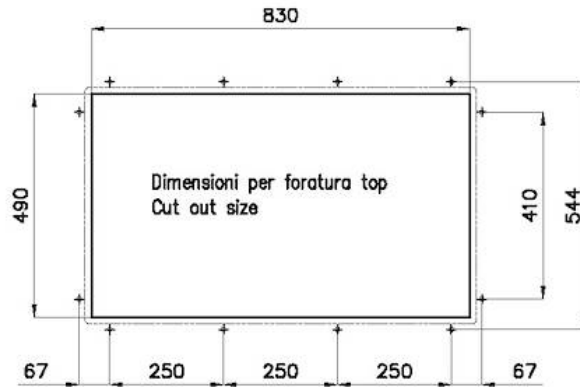

GALLERY

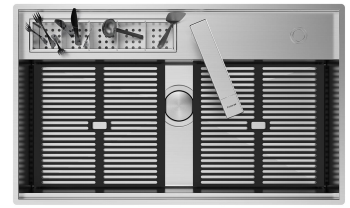
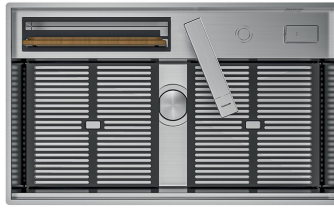

EQUIPMENT



Black grid
8100 618



Iroko-wood chopping board
8643 117

OPTIONAL ACCESSORIES



Stainless steel perforated tray
8151 004

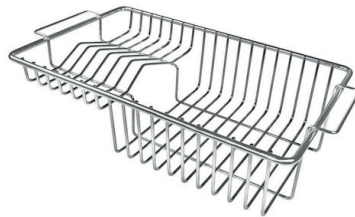

Stainless steel plate rack
8100 305