

Nure Freestanding Bath Filler with Hand Shower

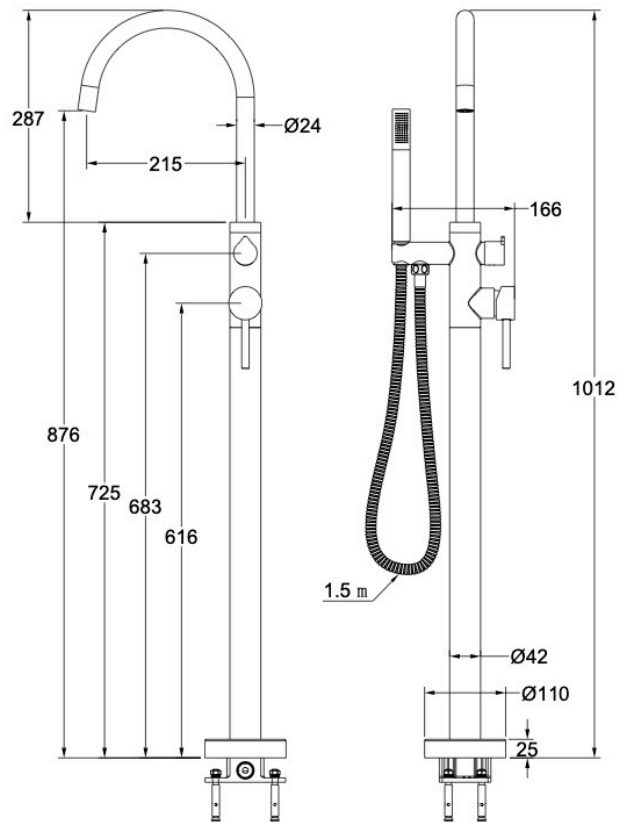

Product Specifications

Code:	NUR-15F-CH
Finish:	Chrome
Barcode:	9339897010382
WELS Star:	3 Star
WELS Rating:	8L/Min
Cartridge:	35mm Cartridge
Spindle/Divertor:	1/4 Turn Ceramic Disc
Primary Material:	304 Stainless Steel
Technical Features:	Mounting: Freestanding Included: In Floor Body
Special Features:	Spare Parts Available



NUR-15F-GM
Gunmetal
PVD



NUR-15F-CH
Chrome
Electroplate



NUR-15F-MB
Matte Black
Electroplate



NUR-15F-BN
Brushed Nickel
Raw Brush



NUR-15F-BB
Brushed Brass
PVD

Experience, *the difference.*



LINSOL.COM.AU

☎ 1300 546 765

✉ info@linsol.com.au

✉ PO Box 88, Coniston NSW 2500

All information is correct at time of writing. The actual product may vary slightly and sizes may be scaled up or down. Warranty is for domestic use only. For warranty & care information please visit linsol.com.au/warranty